

VULCAN

*SERVICE AND PARTS MANUAL FOR
H SERIES
HEAVY DUTY GAS RANGES
FORMERLY 7800 AND SG7800 SERIES*



VULCAN-HART COMPANY, P.O. BOX 696, LOUISVILLE, KY 40201-0696, TEL. (502) 778-2791

FORM 30555 (2-91)

IMPORTANT

OPERATING, INSTALLING AND SERVICE PERSONNEL

Operating information for this equipment has been prepared for use by qualified and/authorized operating personnel.

All installation and service on this equipment is to be performed by qualified, certified, licensed and/authorized installation or service personnel, with the exception of any part marked with a in front of the part number.

Service may be obtained by contacting the Factory Service Department, Factory Representative or Local Service Agency.

DEFINITIONS

QUALIFIED AND/OR AUTHORIZED OPERATING PERSONNEL

Qualified or authorized operating personnel are those who have carefully read the information in this manual and are familiar with the equipment's functions or have had previous experience with the operation of the equipment covered in this manual.

QUALIFIED INSTALLATION PERSONNEL

Qualified installation personnel are individuals, a firm, corporation or company which either in person or through a representative are engaged in, and are responsible for:

1. The installation of gas piping from the outlet side of the gas meter, or the service regulator when the meter is not provided, and the connection and installation of the gas appliance. Qualified installation personnel must be experienced in such work, be familiar with all precautions required, and have complied with all requirements of state or local authorities having jurisdiction. Reference in the United States of America – National Fuel Gas Code ANSI Z223.1 (Latest Edition). In Canada – Canadian Standard CAN/CGA-B149.1 NAT. GAS (Latest Edition) or CAN/CGA-B149.2 PROPANE GAS (Latest Edition).
2. The installation of electrical wiring from the electric meter, main control box or service outlet to the electric appliance. Qualified installation personnel must be experienced in such work, be familiar with all precautions required, and have complied with all requirements of state or local authorities having jurisdiction. Reference: In the United States of America – National Electrical Code ANSI NFPA No. 70 (Latest Edition). In Canada – Canadian Electric Code Part 1 CSA-C22.1 (Latest Edition).
3. The installation of steam piping from the source of supply to the service inlet of the appliance. Qualified installation personnel must be experienced in such work, be familiar with all precautions required, and have complied with all requirements of state or local authorities having jurisdiction.

QUALIFIED SERVICE PERSONNEL

Qualified service personnel are those who are familiar with Vulcan equipment who have been endorsed by the Vulcan-Hart Corporation. All authorized service personnel are required to be equipped with a complete set of service and parts manuals and stock a minimum amount of parts for Vulcan equipment.

SERVICE AND PARTS MANUAL FOR H SERIES GAS RANGES

INDEX

(Formerly 7800 & SG-7800 Series)

PLEASE KEEP THIS MANUAL FOR FUTURE REFERENCE

DESCRIPTION	PAGE
DEFINITIONS OF PERSONNEL (OPERATING, INSTALLATION & SERVICE)	Inside Front Cover
INDEX	3
TROUBLESHOOTING (PROBLEMS AND CAUSES)	4
LIGHTING AND SHUTTING DOWN PILOT BURNERS	5, 6
PILOT BURNER ADJUSTMENTS	7
STANDARD OVEN TEMPERATURE CONTROL RECALIBRATION	8
CONVECTION OVEN TEMPERATURE CONTROL RECALIBRATION	8
AUTOMATIC SHUTOFF PILOT INSTRUCTIONS	9
REPLACEMENT PARTS LIST AND PHOTOS	10-25
REPLACEMENT PARTS DRAWING (INSERT A)	17
REPLACEMENT PARTS DRAWING (INSERT B)	18

A rating plate is located on the control panel of this unit (alternate location is behind the lower front cover attached to the burner box area). The rating plate states the model number, serial number and type of gas unit requires.

Motors in Vulcan convection ovens are permanently lubricated and require no additional maintenance.

TROUBLESHOOTING

PROBLEM	PROBABLE CAUSES
OVEN	
TOO MUCH BOTTOM HEAT	INSUFFICIENT HEAT INPUT. OVERACTIVE FLUE.
UNEVEN BAKE	TOO LOW TEMPERATURE. IMPROPER OPERATION.
SIDE BURNING	IMPROPER BYPASS SETTING. FLUCTUATING GAS PRESSURE.
TOO MUCH TOP HEAT	TOO HIGH TEMPERATURE. FAULTY VENTILATION. EXCESSIVE HEAT INPUT. THERMOSTAT NEEDS CALIBRATION.
UNEVEN BAKE - SIDE TO SIDE	APPLIANCE NOT LEVEL SIDE TO SIDE. OVEN BURNER, BOTTOM OR BAFFLES IMPROPERLY INSTALLED.
PULLING TO EDGE OF PAN	WARPED PANS. OVEN NOT LEVEL.
UNEVEN BAKE - FRONT TO REAR	OVERACTIVE FLUE. UNIT NOT LEVEL, FRONT TO BACK. DOOR NOT CLOSING PROPERLY.
DRIED OUT PRODUCTS	TOO LOW TEMPERATURE. TOO LONG BAKING TIME. THERMOSTAT CALIBRATION.
PILOT OUTAGE	GAS SUPPLY NOT SUFFICIENT. PILOT FLAME TOO LOW. RESTRICTION IN PILOT ORIFICE. MALFUNCTIONING SAFETY VALVE.
	CONVECTION OVEN MODELS ONLY: CAVITY LEAKING. GASKET PROBLEMS. SNORKEL® TUBE BLOCKED. BLOWER RUNNING BACKWARDS.
EXCESSIVE MEAT SHRINKAGE	ROASTING TEMPERATURE TOO HIGH.
TOP BURNER OPERATION	
IMPROPER BURNER COMBUSTION EXCESSIVE VALVE HANDLE TEMPERATURES STICKING TOP BURNER VALVES	IMPROPER USE, ALLOWING IMPROPER VENTILATION. POOR DOOR FIT. OVEN DOOR LEFT OPEN.
POOR IGNITION	INSUFFICIENT INPUT. POOR AIR-TO-GAS ADJUSTMENT. RESTRICTION IN PILOT ORIFICE. RESTRICTION IN MAIN BURNER IGNITION PORT. RESTRICTION IN CONTROL VALVE. RESTRICTION IN GAS ORIFICE.

LIGHTING AND SHUTTING DOWN PILOT BURNERS

NOTE: All adjustment procedures associated with pilot lighting must be performed by an authorized Vulcan-Hart installation or service person. The bypass (minimum burner) flame adjustment must be made at the time the appliance is installed.

OPEN TOP BURNERS

1. Turn main gas supply ON.
2. Wait 30 seconds, and using a taper, light the open top pilot.
3. If pilot fails to light, turn main gas supply OFF. Wait 5 minutes and repeat the above procedures.
4. Turn one open top burner valve ON to remove air from the remaining unit gas lines. Turn the burner OFF when the gas begins to flow.

Nightly Shutdown

Turn oven burner valve OFF; pilot will remain lit.

Complete Shutdown

1. Turn burner valve OFF; pilot will remain lit.
2. Turn main gas supply OFF.

GRIDDLE TOPS/HOT TOPS

1. Turn main gas supply ON.
2. Wait 30 seconds, and using a taper, light the griddle pilot.
3. If pilot fails to light, turn main gas supply OFF. Wait 5 minutes and repeat Steps 1 through 3.
4. Turn one hot top or griddle top burner valve ON to remove air from the gas line. Turn burner valve OFF when gas begins to flow.

Nightly Shutdown

Turn burner valve OFF; pilot will remain lit.

Complete Shutdown

1. Turn burner valve OFF; pilot will remain lit.
2. Turn main gas valve OFF.

LIGHTING AND SHUTTING DOWN PILOT BURNERS (Cont.)

STANDARD OVEN PILOT

NOTE: Before lighting oven, be sure that range top sections have been lit.

1. Open oven door and lift up the pilot lighting hole cover.
2. Light oven pilot by depressing red reset button (Fig. 1) located on the side control panel above the thermostat knob. Light the pilot and continue to hold the reset button in for one minute.

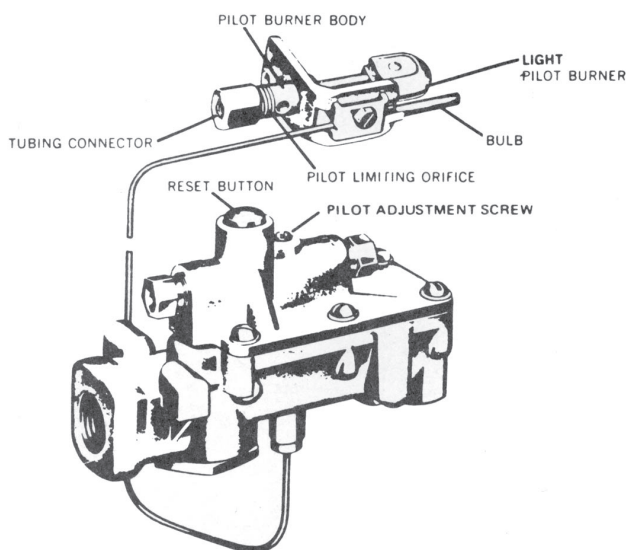

Fig.1

3. If pilot fails to light, turn main gas supply OFF and wait 5 minutes before repeating Steps 1 and 2.
4. After pilot is lit, close lighting hole cover and oven door.
5. Set oven thermostat to desired temperature.

Nightly Shutdown

Turn oven burner valve OFF.

Complete Shutdown

1. Turn burner valve OFF.
2. Turn main gas supply OFF.

CONVECTION OVEN PILOT

NOTE: Before lighting oven, be sure that range top sections have been lit.

1. Connect unit to the main electrical supply line. Open oven door panel and lift up the pilot lighting hole cover.
2. Turn red gas valve (located behind the control panel) ON, purging the gas line of all air. Turn gas valve and power switch OFF. Close oven door.
3. Light oven pilot by depressing the red pilot reset button (see Fig. 1), and using a taper, ignite the pilot. Hold reset button in for 30 seconds, or until pilot remains lit. Turn gas valve back ON.
4. If pilot fails to light, turn main gas supply OFF. Wait 5 minutes and repeat Steps 2 and 3.
5. After pilot is lit, push the power switch ON and turn the temperature dial to the desired setting.

Nightly Shutdown

Turn power switch OFF and the temperature dial to 0 degrees.

Complete Shutdown

1. Push power switch OFF.
2. Turn red gas valve (located behind the control panel) OFF.
3. Turn main gas supply OFF.
4. Disconnect electrical supply cord.

PILOT BURNER ADJUSTMENTS

NOTE: All pilot adjustments are to be performed only by certified Vulcan service representatives.

OPEN TOP BURNER PILOT ADJUSTMENTS

TOOLS: Standard screwdriver.

After pilot is lit, turn the open top burner(s) ON. Adjust the flame if necessary. To adjust, rotate the pilot valve adjustment screw provided on the unit manifold pipe. Turn the burner ON; burner flame should appear on the burner head within a second. Rotate the screw clockwise to decrease and counterclockwise to increase the flame.

Check the open top burner nozzle relationship. The burner nozzle should enter approximately $\frac{1}{4}$ " inside the burner venturi (Fig. 2).

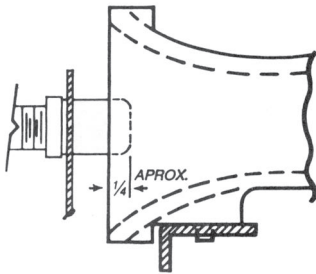

Fig. 2

HOT TOP AND GRIDDLE TOP PILOT ADJUSTMENTS

TOOLS: Standard flat blade screwdriver.

After pilot is lit, adjust the burner flame, if necessary. This is accomplished by rotating the adjustment screw of the pilot valve located on the manifold pipe. Turn the burner ON; burner flame should appear on the burner head within a second. Rotate adjustment screw clockwise to decrease and counterclockwise to increase the flame.

OVEN ADJUSTMENTS

TOOLS: Standard flat blade screwdriver.

There are two different adjustments to check for in the oven section: pilot safety, and bypass.

Pilot Safety Adjustment

With control panel cover removed, light the oven pilot as explained in the oven lighting instructions. If pilot goes out, increase the pilot safety adjustment until the flame completely engulfs the safety device sensing bulb. The safety adjustment screw is located on the safety control below the red button.

Bypass Flame Adjustment (Oven and Thermostatically Controlled Griddle)

NOTE: This adjustment must be made at time of appliance installation.

Ignite oven/griddle burner pilot. With oven/griddle cold, turn the thermostat dial slowly clockwise until main burner gas is heard snapping ON. Remove the dial. With a screwdriver, turn the bypass adjustment screw (Fig's. 3 & 4) counterclockwise to increase the bypass flame, or clockwise to decrease it, until flame over the entire burner is approximately $\frac{1}{8}$ " high. The bypass adjustment screw is located to the left-hand side of the thermostat control for the oven section, and on top of the thermostat control for the griddle. After adjustment has been made, replace dial.

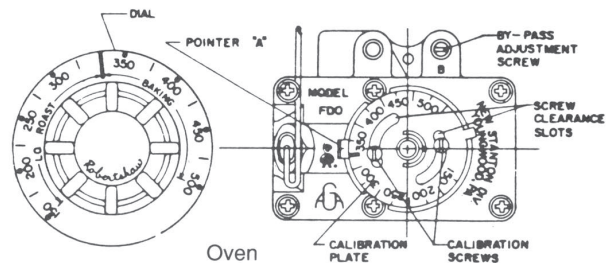

Fig. 3

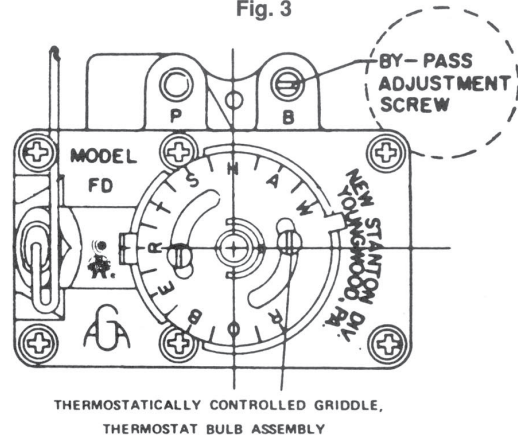

Fig. 4

TEMPERATURE CONTROL RECALIBRATION

STANDARD OVEN TEMPERATURE CONTROL RECALIBRATION

Field recalibration is seldom necessary and should not be resorted to unless experience with cooking results definitely proves that the control is not maintaining the set temperature. To check oven temperatures when recalibrating, use a Robertshaw Test Instrument or a reliable mercury oven thermometer.

1. Place thermocouple of test instrument or thermometer in the middle of the oven. Close oven door.
2. Light main burner.
3. Turn dial to any temperature setting and allow oven to heat until flame cuts down to bypass. Let cycle several times.
4. After burner has been on sufficiently long enough to cut down the bypass flame, check oven temperature. The control should be recalibrated if your reading is not within 15° F of the dial setting. If recalibration is required, proceed as follows:
5. Remove dial.
6. With a screwdriver, loosen the two calibration screws (Fig. 5) until calibration plate moves independently of the control.
7. Turn calibration plate until mark corresponding to test instrument or thermometer reading is in line with center of pointer "A" (Fig. 5), and while holding in this position, tighten calibration screws firmly.
8. Replace dial.
9. **NOTE:** If the above adjustment is prevented by the two loosened calibration screws being in contact with the ends of the screw clearance slots in the calibration plate, remove the screws, and after turning the calibration plate to the proper location, reassemble screws in the other tapped holes designed for them.

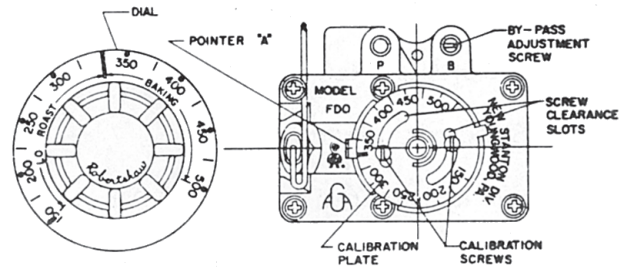
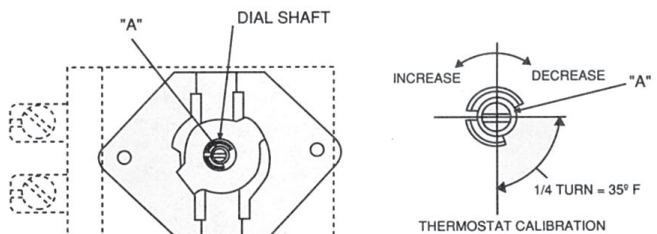

Fig. 5

CONVECTION OVEN TEMPERATURE CONTROL RECALIBRATION

1. Place thermocouple of test instrument in middle of oven. Close oven door.
2. Light the main burner by turning thermostat dial to any temperature setting.
3. Allow oven to heat until flame cuts off. After several cycles, check temperature. If the temperature does not read within 15° F of the dial setting, recalibrate as follows:
4. Pull dial straight off dial shaft without turning (Fig. 6).
5. Turn screw "A" clockwise to decrease temperature and counterclockwise to increase temperature (Fig. 6).

NOTE: 1/4 turn of Screw "A" represents a temperature shift of 35° F.



PL-50119

Fig. 6

AUTOMATIC SHUTOFF PILOT INSTRUCTIONS

CLEANING

To clean limiting orifice (Fig. 7), turn gas supply to unit OFF. Disconnect pilot tubing at the pilot burner body. The orifice is then accessible at the body end of the pilot burner and can be removed for cleaning. Clean spud, taking care not to enlarge the orifice hole.

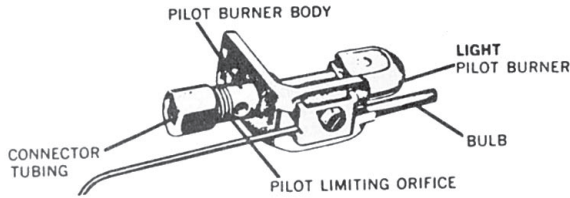

Fig. 7

SERVICE INSTRUCTIONS (Fig. 8)

1. If valve fails to open with good pilot flame impingement, replace valve.
2. Do not remove interrupter valve for field service.

NOTE: Make certain gas line to inlet of control is purged of air and that gas flow is available at this point.

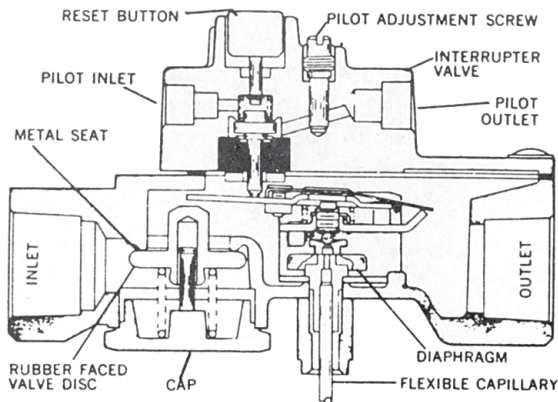

Fig. 8

THERMOSTATICALLY CONTROLLED GRIDDLE RECALIBRATION

Field recalibration is seldom necessary and should not be resorted to unless cooking results definitely prove that griddle surface temperature and thermostat setting do not agree. To check griddle temperature, use an accurate "surface temperature thermometer" in the following manner.

1. Locate thermometer in center of griddle from front to rear: on 17" wide units, use one thermometer and center from side to side; on 34" wide units, use two thermometers, one 8- $\frac{1}{2}$ " from each side of the griddle.
2. Set thermostat dial to any temperature and allow griddle to heat thoroughly. When the griddle is completely heated and the burner is on bypass gas, check the thermometer reading against the thermostat dial setting. If the difference between the readings exceeds 15° F, the thermostat should be recalibrated. Example: With the thermostat dial at 400° F and a thermometer reading of less than 385° F or more than 415° F, the thermostat should be recalibrated.

Recalibration Procedure

Make note of number of degrees thermostat is off. Remove thermostat dial and loosen calibration screws (Fig. 9) until plate moves freely. Turn calibration plate the required number of degrees counterclockwise if the thermometer reading was higher than the dial setting, or clockwise if the thermometer reading was lower than the dial setting. Hold calibration plate in desired position and tighten plate screws firmly. The number of degrees between letters on the calibration plate is 50° F.

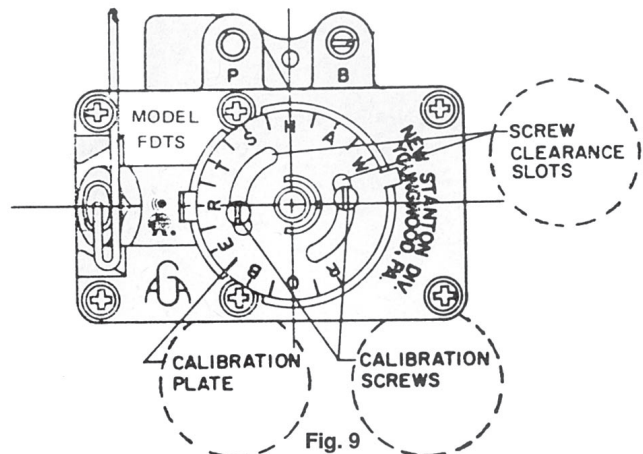

Fig. 9

REPLACEMENT PARTS LIST

WARNING ALL SERVICE PERSONNEL

WHEN SERVICING THIS EQUIPMENT, USE ONLY CERTIFIED CONTROLS DUPLICATING THOSE ORIGINALLY SUPPLIED ON THIS EQUIPMENT BY VULCAN-HART COMPANY.

DO NOT SUBSTITUTE COMPONENTS WITH DIFFERENT MODEL NUMBERS.

DO NOT SUBSTITUTE COMPONENTS WITH DIFFERENT MANUFACTURING NAMES.

DO NOT SUBSTITUTE COMPONENTS WITH REBUILT CONTROLS WITHOUT AUTHORIZATION FROM VULCAN-HART CORP. ANY UNAUTHORIZED SUBSTITUTION OF CONTROLS AS STATED ABOVE MAY BE A HAZARD AND WILL AUTOMATICALLY VOID THE WARRANTY AND THE CERTIFICATION ASSOCIATED WITH THIS EQUIPMENT.

Replacement parts orders:

The following information must accompany a replacement parts order or it cannot be filled.

- A. Model and serial number
- B. Type of gas
- C. Unit voltage, ampage and motor phase
- D. Appliance finish black, gray, stainless steel etc.

This information may be found on the unit rating plate located on the control panel (alternate location is behind the lower front cover attached to the burner box area). Parts may be ordered from your dealer, service agency, or parts distributor. For further information concerning parts ordering location, contact Vulcan-Hart Company, 3600 North Point Blvd. Baltimore, Maryland 21222, or in Canada, Vulcan-Hart Canada Incorporated, 79 West Street South Orillia, Ontario L3V 6K5.

Note: NS = Not Shown By Photo or Diagram

REPLACEMENT PARTS LIST

H SERIES RANGE REPLACEMENT PARTS LIST

ALL UNITS WITH OVENS

ITEM NUMBERS REFER TO REPLACEMENT PARTS DRAWING AND PHOTOS OF INSERT B & A

Item	Std. Oven	Conv. Oven Part Numbers (Formerly SG 7800)	Description Part Numbers (Formerly 7800)	Remarks
1	407798-4	407798-4	Safety Valve	
2	407522-1		FDO Thermostat (Oven)	N.S
3	407789-1		Oven Valve	
4	409819-G2	411497-F1	Solenoid Valve	N.S.
			Oven Burner	
		413957-1	Oven Burner	N.S.
5	409125-10	409125-10	Oven Pilot Burner (Natural)	H45
6	417429-G1	417429-G1	Oven Door Spring	
	413091-1	413091-1	"J" Hook	N.S.
	413090-1	413090-1	Spring Bracket	N.S.
8	405618-1	405618-1	Right Door Hook	N.S.
	405618-2	405618-2	Left Door Hook	
9	403956-1	403956-1	Bell Crank	
10	402957	402957	Plated Valve Handle	
10.1	402958		Red Valve Handle	
11	417862-9	417862-9	Hinge Pin	One Used On Convection Oven
		417862-8	Hinge Pin	
12	404629-2	404629-2	Hinge Pin Bearing	
13	RS-32-89	RS-32-89	Bell Crank Pin	
14	404074-2		Oven Rack	
		413991-1	Oven Rack	N.S.
15	405123-G3		Oven Bottom	N.S.
16	405124-5		Oven Bottom Baffle	
16.1	409787-1		Oven Bottom Insulating Pan	(PTD)
	409787-2		Oven Bottom Insulating Pan	(SST)
17	405928-4		Oven Bottom Foil Insulation	
18	409793-1	409793-1	Oven Door Handle	
19	409790-1	409790-1	Right Hand Door Post	
19.1	409790-2	409790-2	Left Hand Door Post	
20	400705-1	400705-1	Ring	H30
21	406460-1	406460-1	Lid	H30
22	405817-1	405817-1	Half Cover Plate	H30
23	409414-G1	409414-G1	Inner Burner	H30
24	409413-G1	409413-G1	Middle Burner	H30
25	409412-G1	409412-G1	Outer Burner	H30
26	409839-1	409839-1	Top Burner Pilot (Nat)	H30
	409839-2	409839-2	Top Burner Pilot (Mfg)	H30
	409839-3	409839-3	Top Burner Pilot (LP)	H30
	409839-4	409839-4	Orifice .018 (Nat)	H30
	409839-5	409839-5	Orifice .024 (Mfg)	H30
	409839-6	409839-6	Orifice .010 (LP)	H30
27	409557-3	409557-3	Top Pilot Valve	H30, H45, H72, H60
27.1	409557-4	409557-4	$\frac{3}{16}$ Top Pilot Valve	H56, H54, H53-72
27.2	404738-2	404738-2	$\frac{3}{16}$ Single Top Pilot Valve	H56, H54, H53-72
28	402601-F	402601-F	Top Burner Valve	H30

REPLACEMENT PARTS LIST (Cont.)

29	409433-1	409433-1	Top Aeration Plate	H45
30	409432-1	409432-1	Top Grate	H45
31	409416-1	409416-1	Burner Venturi (Lower)	H45
31.1	409417-1	409417-1	Burner Head (Top)	H45
32	402077-2	402077-2	Top Burner Valve	H60
33	FP86-44	FP86-44	Elbow	H60
34	408379-2	408379-2	Top Burner Valve	H45
34.1	408379-1	408379-1	Top Burner Valve	H56, H54, H53-72
35	404772-1	404772-1	Top Plate	H72
37	410889-G40	410889-G40	Griddle Plate Assembly	H60
38	405831-G3	405831-G3	Hot Top Burner	H60
39	404193-1	404193-1	Top Pilot Valve	H60
40	408379-2	408379-2	Top Burner Valve	H60, H72
41	409316-1	409316-1	Top Thermostat	H60
42	410889-G36	410889-G36	17" Griddle Assembly	H60-45
43	405157-G2	405157-G2	Brick Set	H30
44	405848-1	405848-1	Center Brick	H60, H72
44.1	405848-2	405848-2	Center Brick	H60
45	406241-1	406241-1	Side Brick	H60, H72
46	409808-1	409808-1	Manifold Cover (PTD)	H60
	409808-2	409808-2	Manifold Cover (SST)	H60
	409808-3	409808-3	Manifold Cover (PTD)	H72
	409808-4	409808-4	Manifold Cover (SST)	H72
47	409652-1	409652-1	Manifold Cover (PTD)	H30, H51
	409652-2	409652-2	Manifold Cover (SST)	H30, H51
48	409692-1	409692-1	Manifold Cover (PTD)	H45
	409692-2	409692-2	Manifold Cover (SST)	H45
48.1	413856-1	413856-1	Manifold Cover	H56, N.S.
49	413747-1	413747-1	Burner Tray Handle (PTD)	H45, H56
	413747-2	413747-2	Burner Tray Handle (SST)	H45, H56
49.1	413746-1	413746-1	Burner Tray Handle Supports	
49.2	409888-1	409888-1	Tray, Burner (BB)	H45
	409888-2	409888-2	Tray, Burner (SST)	H45
	409888-5	409888-5	Tray, Burner (BB)	H54
	409888-6	409888-6	Tray, Burner (SST)	H54
	409888-9	409888-9	Tray, Burner (BB)	H60, H72
	409888-10	409888-10	Tray, Burner (SST)	H60, H72
50	400149	400149	Lid Lifter	H30
51	409682-G1	409682-G1	Grease Collector (PTD)	H60
	409682-G2	409682-G2	Grease Collector (SST)	H60
52	409778-G1	409778-G1	RH Side Lining (BLK)	
	409778-G2	409778-G2	LH Side Lining (BLK)	
	409778-G3	409778-G3	RH Side Lining (SST)	
	409778-G4	409778-G4	LH Side Lining (SST)	
	409778-G5	409778-G5	RH Side Lining (Cont. Clean)	
	409778-G6	409778-G6	LH Side Lining (Cont. Clean)	
53	409791-G1	409791-G3	Oven Door Assembly (BLK)	
	409791-G2	409791-G4	Oven Door Assembly (SST)	
54	413776-G1	413776-G1	Rear Burner Assembly	H56
55	413776-G2	413776-G2	Front Burner Assembly	H56
56		413979-1	Oven Rack Support	N.S.

REPLACEMENT PARTS LIST (Cont.)

57		414001-1	Air Director	N.S.
58		413990-G1	Fan Cover Assembly	N.S.
59		415780-7	Fan	N.S.
60		413994-1	Motor	N.S.
62	413773-1	413773-1	Top Grate	H56, H54, H53-72
63	413787-1	413787-1	Nozzle Extension	H56, H54
64		411496-B1	On/Off Switch	N.S.
65		411496-E4	Warning Light	N.S.
66		405016-1	Supple Cord	N.S.
67	415285-G2	415285-G2	Aeration Plate Assembly	H54
67.1	415285-G1	415285-G1	Aeration Plate Assembly	H56
68	415289-G1	415289-G1	Aeration Plate Assembly	H53-72
69	413780-1	413780-1	Burner Support Channel	H54, H53-72
70	414448-1	414448-1	Burner Support Bracket(NS)	H54, H56, H53-72
71	413776-G1	413776-G1	Rear Burner Assembly	H54
71.1	413776-G2	413776-G2	Front Burner Assembly	H56, H54, H53-72
72	12685-49	12685-49	Straight Fixed Nozzle (Natural)	H54, H56
73	417879-1	417879-1	Straight Fixed Nozzle (Propane)	H54, H56, H53-72
74	413864-1	413864-1	Right Hand Pilot Valve Tube	H54, H56, H53-72
75	413867-1	413867-1	Pilot Valve Tube	H54, H56, H53-72
76	FP-85-41	FP-85-41	$\frac{3}{16}$ Compression Tee	H54, H56
77	413865-2	413865-2	Pilot Tube	H54, H56
78	415246-1	415246-1	Pilot Tube, Right Front	H53-72
79	415247-1	415247-1	Pilot Tube, Left Front	H53-72

REPLACEMENT PARTS LIST (Cont.)

80	415248-1	415248-1	Pilot Tube, Hot Top	H53-72
81	412063-2	412063-2	Top Pilot	H54, H53-72
82	414038-1	414038-1	Hot Top Burner	H53-72
83	414064-1	414064-1	Rear Burner Support	H53-72
84	414282-1	414282-1	Hot Top	H53-72
85	414072-1	414072-1	Rear Baffle	H53-72
86	414067-G1	414067-G1	Center Support Hanger Assy.	H53-72
87	414071-G1	414071-G1	Center Support Assembly	H53-72
48.2	413856-5	413856-5	Manifold Cover	H53-72
48.3	413856-3	413856-3	Manifold Cover	H54
88	404079-A32	404079-A32	Top Burner Nozzle (Natural)	H45
88.1	404079-F52	404079-F52	Top Burner Nozzle (Propane)	H45
89	409805-1	409805-1	Rear Burner Tubing Right Hand	H45
90	409870-1	409870-1	Front Burner Tubing, Lt. Hd.	H45
91	409806-1	409806-1	Rear Burner Tubing, Lt. Hd.	H45
92	409807-1	409807-1	Front Burner Tubing, Rt. Hd.	H45
93	415044-1	415044-1	Burner Clip	H45
94	404060-3	404060-3	Mixer Slide Fanner	H45
95	409901-1	409901-1	Venturi Shield	H45
5.1	409125-12	409125-12	Pilot, (Propane)	H45
96	FP-19-8	FP-19-8	¼ x ¼ x ¼ Tee CC Fitting	H45
97	414993-1	414993-1	Pilot Tubing - ¼"	H45
98	414994-1	414994-1	Pilot Tubing - Lt. Hd. ¼"	H45
98.1	414994-2	414994-2	Pilot Tubing - Rt. Hd. ¼"	H45
99	415003-1	415003-1	Pilot Tubing - ¼"	H45
100	414992-G1	414992-G1	Pilot Bracket Assembly	H45

REPLACEMENT PARTS LIST (Cont.)

PART NO.	DESCRIPTION	GAS	BURNER	ORIFICE Drill Size No.
H30 VALVES				
402601-A44	Valve, Top Burner Adj.	Natural	Outer	44 (.086)
402601-F56	Valve, Top Burner Fixed	Butane	Outer	55 (.052)
402601-F55	Valve, Top Burner Fixed	Propane	Outer	54 (.050)
402601-A48	Valve, Top Burner Adj.	Natural	Middle	48 (.076)
402601-F59	Valve, Top Burner Fixed	Butane	Middle	58 (.042)
402601-F57	Valve, Top Burner Fixed	Propane	Middle	56 (.047)
402601-A53	Valve, Top Burner Adj.	Natural	Inner	53 (.060)
402601-F66	Valve, Top Burner Fixed	Butane	Inner	65 (.035)
402601-F64	Valve, Top Burner Fixed	Propane	Inner	63 (.037)
H60 and H72 NOZZLES				
417879-1	Nozzle, Straight Fixed	Propane		55 (.052)
418050-1	Nozzle, Straight Adj.	Natural		44 (.086)
H45 NOZZLES				
404079-A35	Nozzle, Top Burner Adj .	Natural		32 (.116)
404079-F53	Nozzle, Top Burner Fixed	Butane		1/16 (.062)
404079-F52	Nozzle, Top Burner Fixed	Propane		51 (.067)
STANDARD OVEN NOZZLES AND PILOT BURNERS				
417840-1	Nozzle, Oven Burner, Fixed	Propane		48 (.076)
417840-1	Nozzle, Oven Burner, Fixed	Butane		49 (.073)
417840-2	Nozzle, Oven Burner, Adj.	Natural		26(.147)
409125-1	Pilot Burner, Oven	Natural		77(.018)
409125-3	Pilot Burner, Oven	Propane		(.009)
STANDARD TOP PILOT BURNERS				
409839-1	Pilot Burner	Natural		77 (.018)
409839-3	Pilot Burner	Propane		(010)
H53-72, H54, and H56 NOZZLES				
417879-1	Nozzle, Straight Fixed	Propane		56 (.046)
12685-49	Nozzle, Straight Adj.	Natural		49 (.073)
CONVECTION OVEN NOZZLES AND PILOT BURNERS				
404079-A36	Nozzle, Oven Burner Adj.	Natural		36 (.106)
404079-F50	Nozzle, Oven Burner Fixed	Propane		50 (.070)
409125-1	Pilot Burner, Oven	Natural		77 (.018)
409125-3	Pilot Burner, Oven	Propane		(.009)

REPLACEMENT PARTS LIST (Cont.)

ITEM	DESCRIPTION	PART NUMBER STD.OVEN (Formally 7800)	PART NUMBER CONV. OVEN (Formally SG-7800)
A	Cover Plate	405817-1	405817-1
B	Back Top (H30, H72 Only) (PTD)	409649-1	409649-1
	Back Top (H30, H72 Only) (SST)	409649-2	409649-2
B1	Back Top (H45) (PTD)	409650-1	409650-1
	Back Top (H45) (SST)	409650-2	409650-2
C	Oven Bottom Baffle	405124-5	—
D	Manifold Cover (H56) (PTD)	413856-1	413856-1
	Manifold Cover (H56) (SST)	413856-2	413856-2
E	Back Top Bracket	409639-1	409639-1
F	Burner Baffle	409787-1	409787-1
G	Manifold Pipe/Gas Connection	405908-1	405908-1
H	Manifold Bracket	405880-1	405880-1
I	Lower Cover (PTD)	409694-1	409694-1
	Lower Cover (SST)	409694-2	409694-2
J	Backguard (Front)	409846-7	409846-7
K	Shipping & Backguard Bracket (PTD)	409639-1	409639-1
	Shipping & Backguard Bracket (SST)	409639-2	409639-2
L	Backguard Bracket (PTD)	408802-G1	408802-G1
	Backguard Bracket (SST)	408802-G2	408802-G2
M	Shelf Connecting Bracket	413881	413881
N	Front Cover (PTD)	409640-G7	409640-G7
	Front Cover (SST)	409640-G8	409640-G8
O	Control Cover Plate (PTD)	407699-3	407699-3
	Control Cover Plate (SST)	407699-4	407699-4
P	Leg (BLK)	409840-1	409840-1
	Leg (SST)	409840-2	409840-2
	Leg, Flanged (BLK)	409840-4	409840-4
	Leg, Flanged (SST)	409840-5	409840-5
D5	Control Manifold Cover (H54) (NS)	413856-3	413856-3
D6	Control Manifold Cover (H53-72) (NS)	413856-5	413856-5

SEE INSERTS A & B

REPLACEMENT PARTS LIST (Cont.) INSERT A

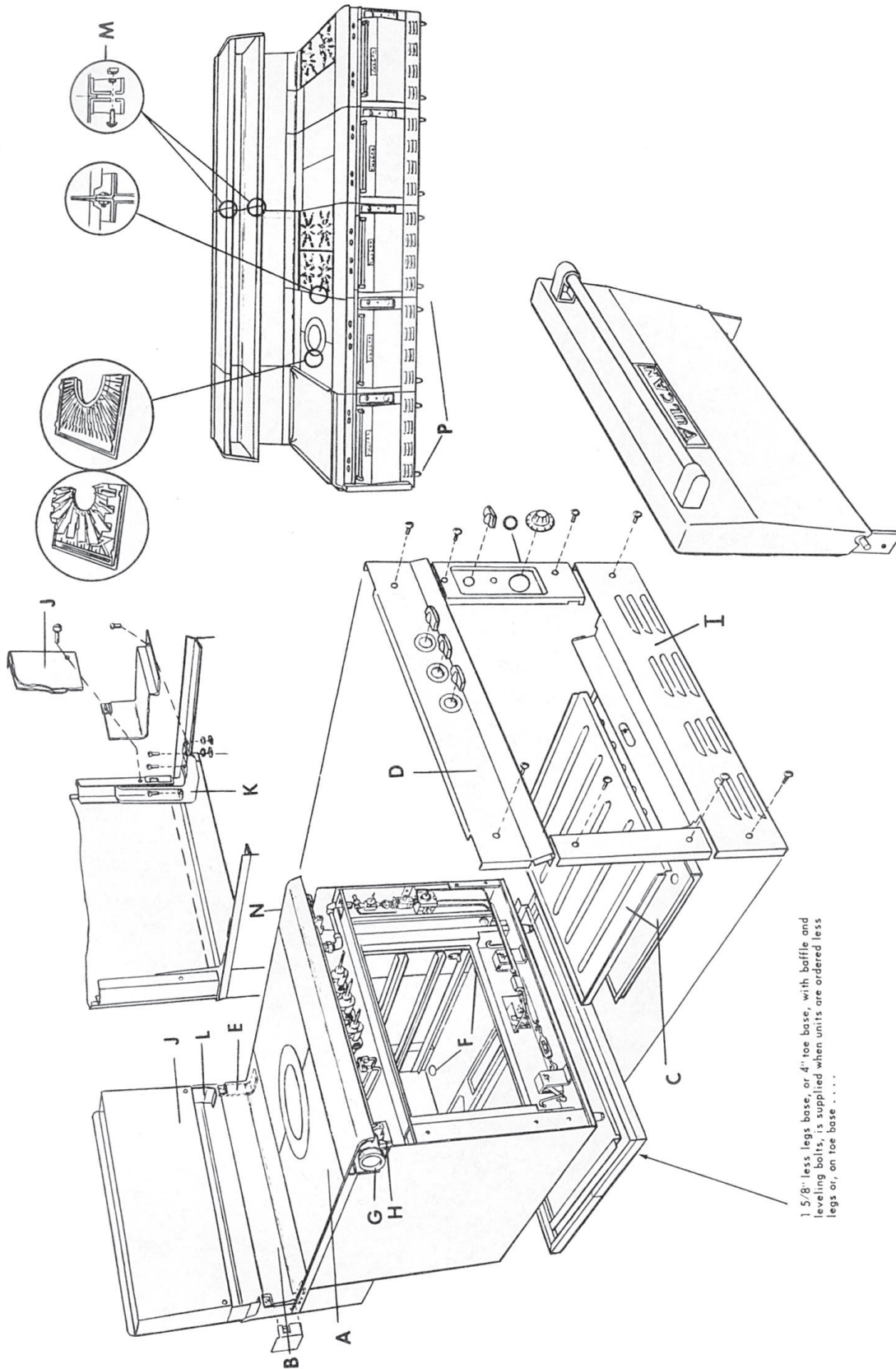

1 5/8" less legs base, or 4" toe base, with baffle and leveling bolts, is supplied when units are ordered less legs or, on toe base

REPLACEMENT PARTS LIST (Cont.) INSERT B

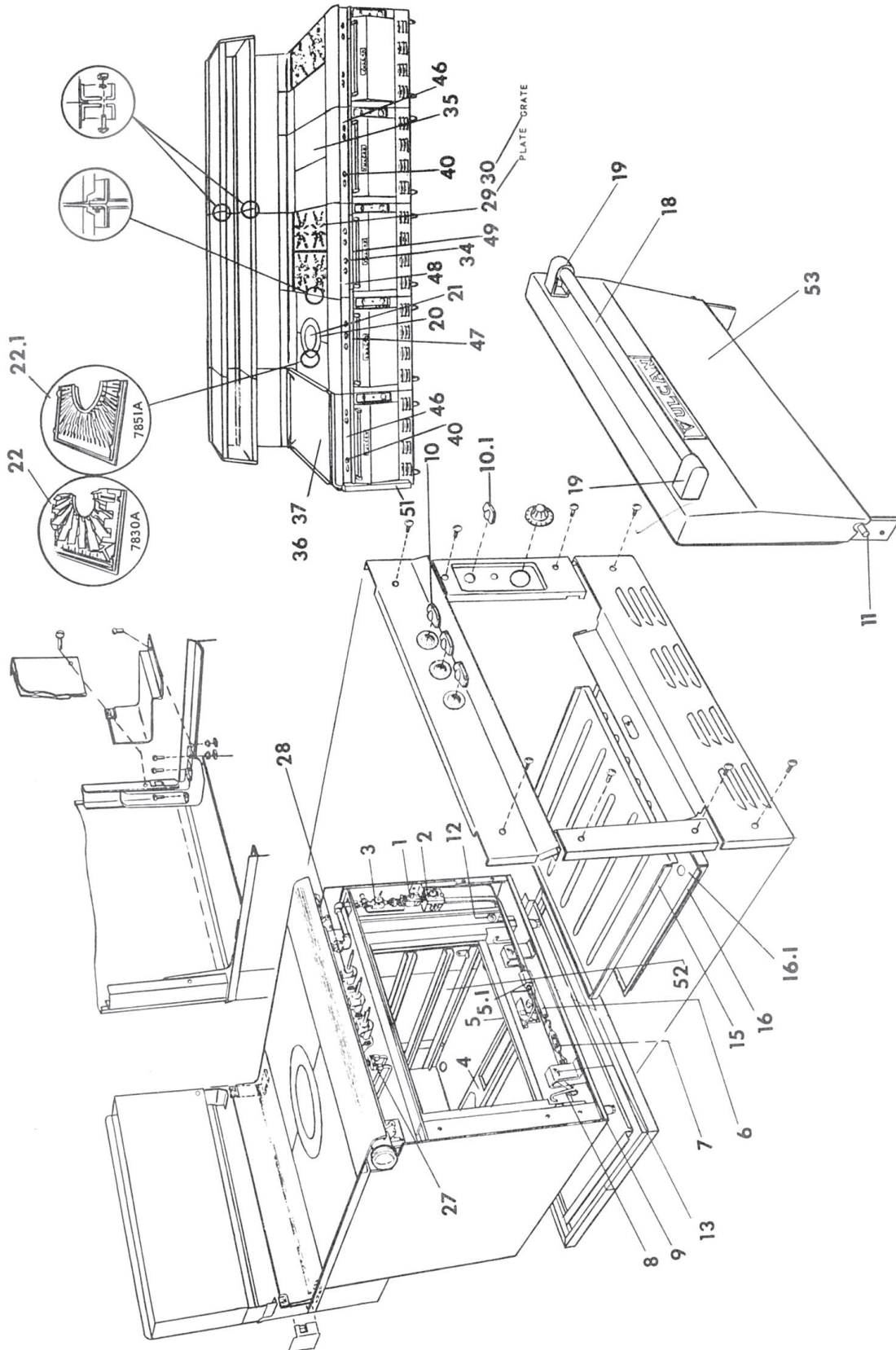

REPLACEMENT PART PHOTOS



H54

REPLACEMENT PART PHOTOS (Cont.)

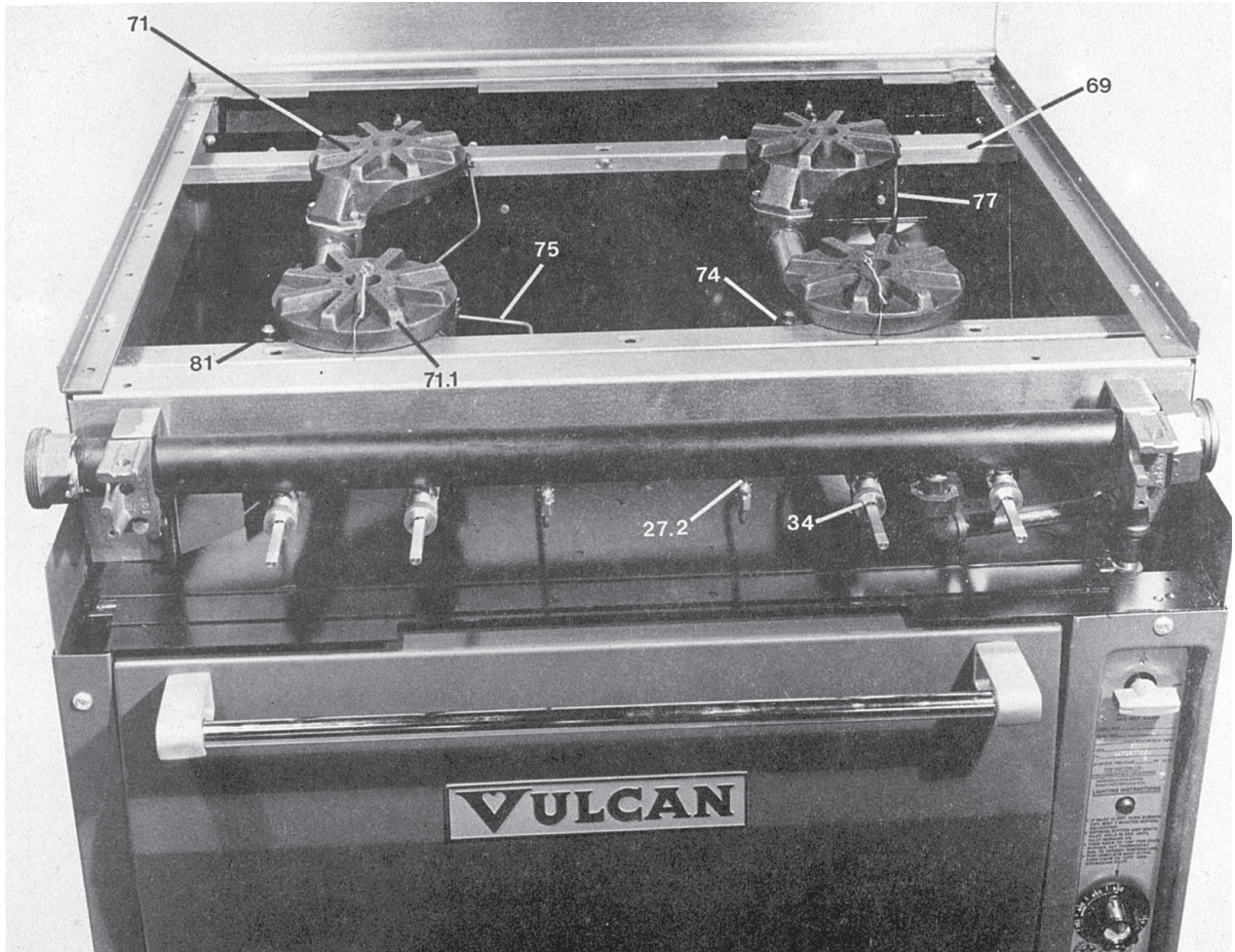

H54

REPLACEMENT PART PHOTOS (Cont.)



H56

REPLACEMENT PART PHOTOS (Cont.)

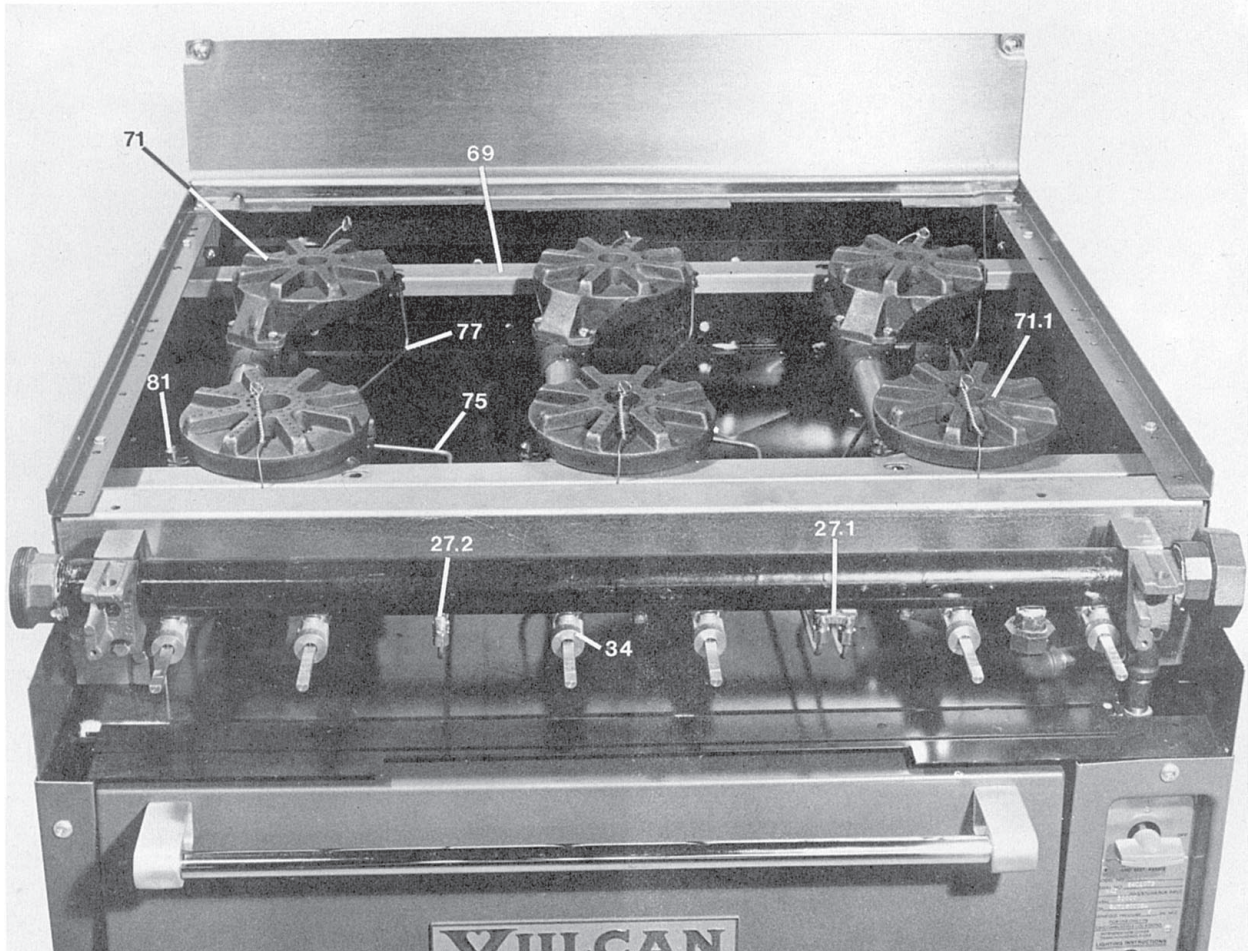

H56

REPLACEMENT PART PHOTOS (Cont.)



H53-72

REPLACEMENT PART PHOTOS (Cont.)

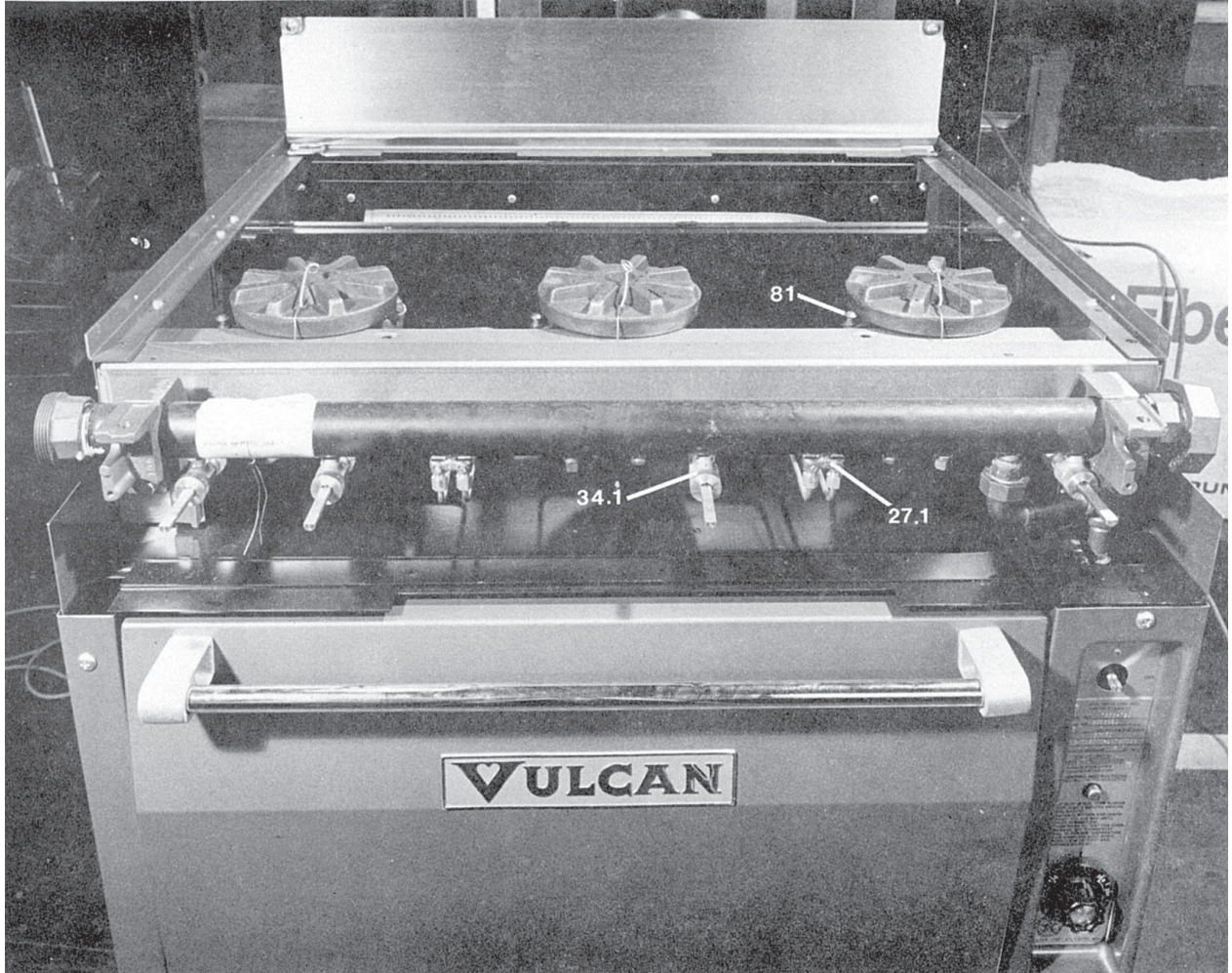

H53-72

REPLACEMENT PART PHOTOS (Cont.)

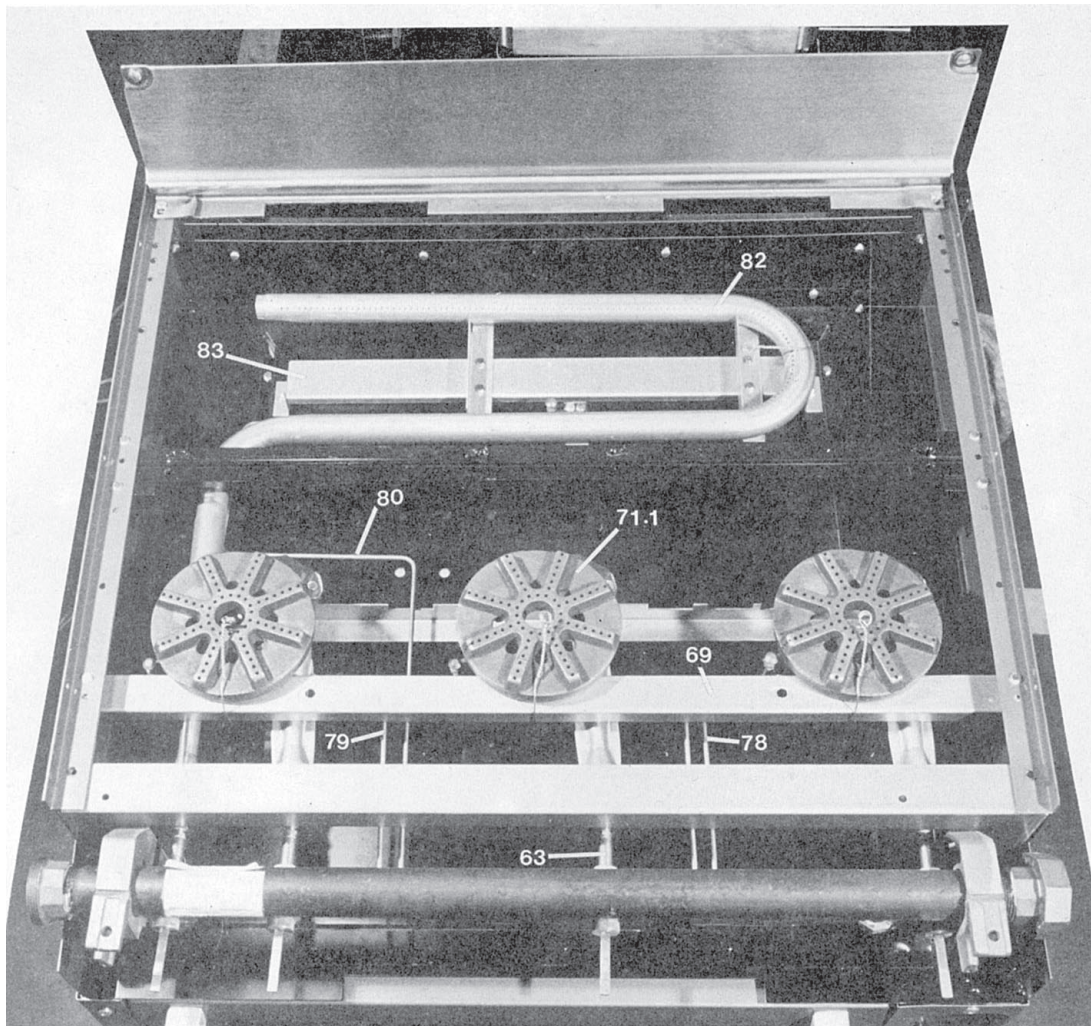

H53-72

THIS
PAGE
INTENTIONALLY
LEFT
BLANK

THIS
PAGE
INTENTIONALLY
LEFT
BLANK

THIS
PAGE
INTENTIONALLY
LEFT
BLANK